

Panasonic

Operating Instructions

Digital Cordless Phone

Model No. **KX-TG1831AL**

Digital Cordless Answering System

Model No. **KX-TG1837AL**

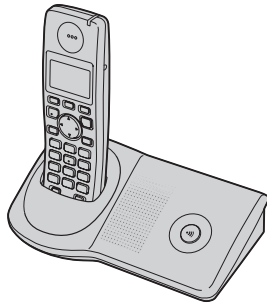

KX-TG1831

SMS



This unit is compatible with Caller ID and SMS. To use these features, you must subscribe to the appropriate service of your service provider/telephone company.

Charge the batteries for about 7 hours before initial use.

Please read these operating instructions before using the unit and save them for future reference.

Introduction

Introduction

Thank you for purchasing a new Panasonic digital cordless phone.

For your future reference

Attach or keep original receipt to assist with any repair under warranty.

Serial No. (found on the bottom of the base unit)

Date of purchase

Name and address of dealer

Note:

- In the event of problems, you should contact your equipment supplier in the first instance.

Your phone

KX-TG1831

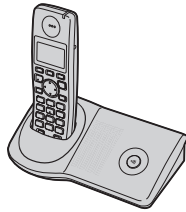

KX-TG1837

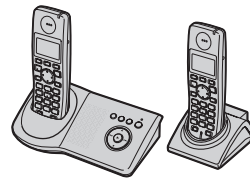

- References in these operating instructions to the charger and multiple handsets are for KX-TG1837 users only.

Note:

- The handsets have been pre-registered for use with their base unit. If not registered, see page 37.

Table of Contents

Preparation

Accessory information 4
 Important information 6
 Instructions to customer 8
 Controls 10
 Displays 11
 Connections 11
 Battery installation/replacement 12
 Battery charge 12
 Turning the power on/off 13
 Symbols used in these operating instructions 14
 Display language 14
 Date and time 14

Making/Answering Calls

Making calls 15
 Answering calls 16

Phonebook

Handset phonebook 17

Handset Settings

Handset settings 19
 Time settings 21

Base Unit Settings

Base unit settings 22
 Call options 23

Caller ID Service

Using Caller ID service 24
 Caller list 24
 Voice mail service 25

SMS (Short Message Service)

Using SMS (Short Message Service) . . . 26
 Turning SMS on/off 26
 Changing SMS message centre numbers . . 26
 Sending a message 27
 Receiving a message 28
 SMS settings 29

Answering System Features (KX-TG1837 only)

Answering system 31
 Turning the answering system on/off . . . 31
 Greeting message 31
 Listening to messages 32
 Direct command operation using the handset 33
 Remote operation 33
 Answering system setting 35

Multi-unit Operation

Operating additional units 37
 Registering a handset to the base unit . . 37
 Intercom between handsets 38
 Transferring calls between handsets, conference calls 38
 Copying phonebook entries 39

Useful Information

Wall-mounting 40
 Using an optional belt clip 41
 Character entry 42
 Error messages 45
 Troubleshooting 45
 Specifications 50

Index

Index 51

Preparation

Accessory information

Included accessories

No.	Accessory items	Quantity	
		KX-TG1831	KX-TG1837
①	AC adaptor for base unit Part No. PQLV207AL	1	1
②	Telephone line cord*1	1	1
③	Telephone plug	1	1
④	Rechargeable batteries AAA size Part No. HHR-4EPT	2	4
⑤	Handset cover*2	1	2
⑥	Charger Part No. PQLV30045	—	1
⑦	AC adaptor for charger*3 Part No. PQLV209CE	—	1

*1 The telephone line cord comes connected with the telephone plug.

*2 The handset cover comes attached to the handset.

*3 The AC adaptor for the charger comes connected with the charger.

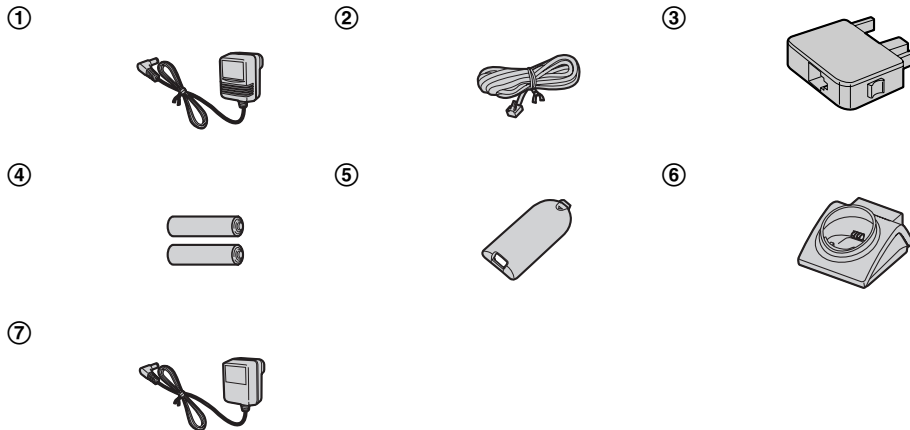

Preparation

Additional/replacement accessories

Model No.	Description
KX-TGA183AZ	Additional Digital Cordless Handset
KX-TCA717EX	Wall-Mounting Adaptor
KX-TCA718EX	Belt Clip
KX-A272 ^{*1}	DECT repeater

*1 Please contact your nearest Panasonic dealer for sales information.

Note:

- When replacing the batteries, use only 2 rechargeable AAA size nickel metal hydride (Ni-MH) batteries. We recommend using Panasonic rechargeable batteries (Model No. HHR-4EPT).
- We cannot be responsible for any damage to the unit or degradation of performance which may occur from using non-Panasonic rechargeable batteries.

Preparation

Important information

General

- Use only the AC adaptor included with this product, noted on page 4.
- Do not connect the AC adaptor to any AC outlet other than a standard 220–240 V AC outlet.
- This product is unable to make calls when:
 - the portable handset battery(ies) need recharging or have failed.
 - there is a power failure.
- Do not open the base unit or handset other than to replace the battery(ies).
- This product should not be used near emergency/intensive care medical equipment and should not be used by people with pacemakers.
- Care should be taken that objects do not fall onto, and liquids are not spilled into, the unit. Do not subject this product to excessive smoke, dust, mechanical vibration or shock.

Environment

- Do not use this product near water.
- This product should be kept away from heat sources such as radiators, cookers, etc. It should also not be placed in rooms where the temperature is less than 5 °C or greater than 40 °C.
- It is advised not to use the equipment at a refuelling point. Users are reminded to observe restrictions on the use of radio equipment in fuel depots, chemical plants or where blasting operations are in progress.
- The AC adaptor is used as the main disconnect device. Ensure that the AC outlet is installed near the unit and is easily accessible.

Warning:

- To prevent the risk of electrical shock, do not expose this product to rain or any other type of moisture.
- Unplug this unit from power outlets if it emits smoke, an abnormal smell or makes unusual noise. These conditions can cause fire or electric shock. Confirm that smoke has stopped and contact an authorised service centre.

Battery caution

- We recommend using the battery(ies) noted on page 5. **Use only rechargeable battery(ies).**
- Do not mix old and new batteries.
- Do not dispose of the battery(ies) in a fire, as they may explode. Check local waste management codes for special disposal instructions.
- Do not open or mutilate the battery(ies). Released electrolyte from the battery(ies) is corrosive and may cause burns or injury to the eyes or skin. The electrolyte may be toxic if swallowed.
- Exercise care when handling the battery(ies). Do not allow conductive materials such as rings, bracelets or keys to touch the battery(ies), otherwise a short circuit may cause the battery(ies) and/or the conductive material to overheat and cause burns.
- Charge the battery(ies) in accordance with the information provided in these operating instructions.
- Only use the included base unit (or charger) to charge the battery(ies). Do not tamper with the base unit (or charger). Failure to follow these instructions may cause the battery(ies) to swell or explode.

Notice

- Please ensure that a separate telephone, not dependent on local power, is available for emergency use.

Preparation

- This equipment will be inoperable when mains power fails.
- When a failure occurs which results in the internal parts becoming accessible, disconnect the power supply cord immediately and return this unit to an authorised service centre.
- To minimise the possibility of lightning damage, when you know that a thunderstorm is coming, we recommend that you:
 - Unplug the telephone line cord from the phone socket.
 - Unplug the power supply cord from the AC power outlet.
- “000” or other calls can be made from this device during a mains power failure.
- **The earcap on the handset is magnetised and may retain metallic objects.**
- This equipment has been tested and found to comply with AS/NZS 3548: 1995 limits for electromagnetic interference. Any modifications to any part of the system or to any peripherals may void the EMC compliance of the system or the peripherals.

Preparation

Instructions to customer

Installation

Attached to this telephone is an approval label. This label is evidence that it is a "Permitted Attachment" which has been authorised to be connected to your telephone service. Conditions relating to connection and operation of this Permitted Attachment are contained in Telecommunications General By-Law 220 (5).

You are authorised to install this Permitted Attachment yourself by plugging it into the line socket of any regular telephone. You may connect it in place of your existing telephone or to any spare telephone socket installed in your premises.

To disconnect your existing telephone you must first remove its plug from the line socket. You can then insert the plug of your Permitted Attachment into the socket and use your equipment.

If the plug of your existing telephone cannot be readily removed, you will have to remove the screw securing it. To do this proceed as follows:

- 1 Loosen screw "A" sufficiently to remove the socket cover. (See Fig. 1.)
- 2 Remove screw "B" and withdraw the plug. (See Fig. 2.)
- 3 Replace screw "B". (See Fig. 3.) Ensure that it screws completely into the socket recess. (If the screw is too long, increase the hole depth or replace the screw with one 5 mm shorter.)
- 4 Replace socket cover and tighten screw "A". (See Fig. 4.)

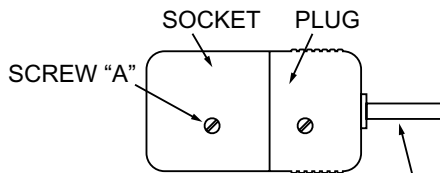

Fig. 1

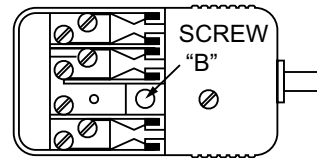

Fig. 2

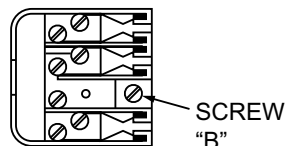

Fig. 3

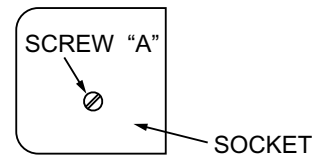

Fig. 4

Preparation

If you are satisfied with the operation of your telephone service after plugging in your Permitted Attachment, your installation is completed.

You will be unable to connect this Permitted Attachment if your telephone service consists only of a wall phone or an old style telephone which is not connected by means of a modern plug and socket. In such cases a new socket will need to be installed.

Should the Permitted Attachment not operate when plugged into a socket, it is either faulty or unsuitable for operation with your telephone service. It should be returned to the store where purchased or to an Authorised Service Centre.

Service difficulties

If at any time a fault occurs on your telephone service carry out the following checks before you call for service:

- Disconnect the Permitted Attachment and try using the service with the normal telephone.
- If the telephone service then operates satisfactorily, the fault is in your Permitted Attachment. Leave the Permitted Attachment disconnected and report the fault to its supplier or agent to arrange for repair.
- If when using the telephone the service is still faulty, report the fault to "Service Difficulties and Faults" for attention.

You are required to keep this Permitted Attachment in good working order while it is connected to your telephone service. Its construction or internal circuit must not be modified in any way without permission.

Warning:

This cordless telephone system does not incorporate provision for secrecy of conversations. Appropriately tuned radio equipment and other cordless telephone systems in close proximity may be used by a third party to monitor and possibly interrupt conversations in progress when this system is on radio operation.

Preparation

Controls

Handset

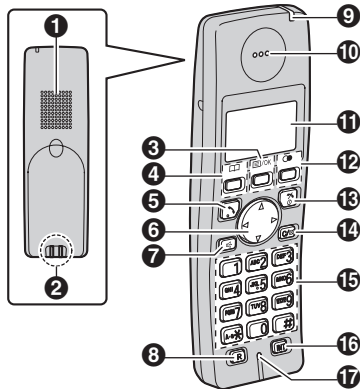

- 1 Speaker
- 2 Charge contact
- 3 [≡/OK] (Menu/OK)
- 4 [☎] (Phonebook)
- 5 [↶] (Talk)
- 6 Navigator key ([▲]/[▼]/[▶]/[◀])
- 7 [☎] (Speakerphone)
- 8 [R] (Recall)
- 9 KX-TG1831
Charge indicator/Ringer indicator
- KX-TG1837
Charge indicator/Ringer indicator/
Message indicator
- 10 Receiver
- 11 Display
- 12 [⏻] (Redial/Pause)
- 13 [⏻] (Off/Power)
- 14 [C/⊗] (Clear/Mute)
- 15 Dial keypad
- 16 [INT] (Intercom)
- 17 Microphone

Base unit (KX-TG1831)

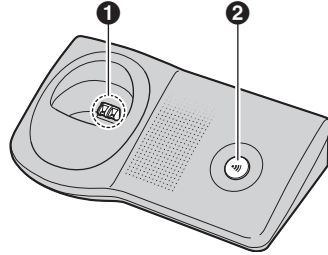

- 1 Charge contact
- 2 [☎] (Page)

Base unit (KX-TG1837)

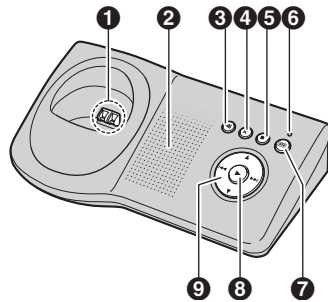

- 1 Charge contact
- 2 Speaker
- 3 [☎] (Page)
- 4 [X] (Erase)
- 5 [■] (Stop)
- 6 Answer on indicator
- 7 [☎] (Answer on)
- 8 [▶] (Play)/Message indicator
- 9 Navigator key: [▲], [▼], [◀], [▶]

Preparation

Displays

Display icons

Display icon	Meaning
	Within range of a base unit <ul style="list-style-type: none"> When flashing: Handset is searching for base unit. (out of range of base unit, handset is not registered to base unit, no power on base unit)
	Handset is accessing base unit. (intercom, paging, changing base unit settings, etc.)
	Handset is on an outside call.
	Answering system is on.* ¹ (page 31)
	Battery strength
[2]	Handset number (page 19)
	New SMS message received* ²
[IN USE]	<ul style="list-style-type: none"> Line is being used by another handset. Answering system is being used by another handset or the base unit.*¹

*1 KX-TG1837 only

*2 SMS users only

Connections

When the AC adaptor is connected, a short beep will be heard. If it is not heard, check the connections.

Base unit

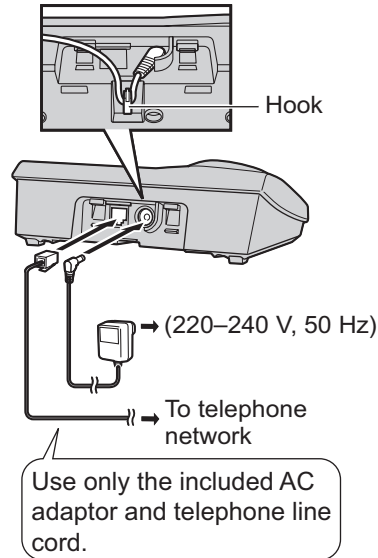

Charger (KX-TG1837 only)

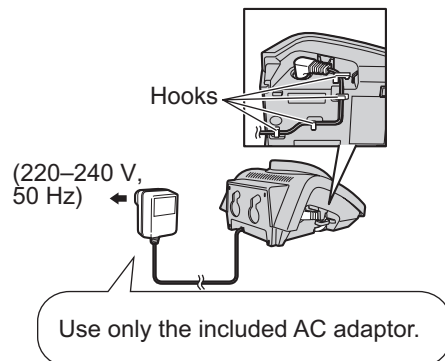

Note:

- Never install telephone wiring during a lightning storm.
- The AC adaptor must remain connected at all times. (It is normal for the adaptor to feel warm during use.)
- The AC adaptor should be connected to a vertically oriented or floor-mounted AC outlet. Do not connect the AC adaptor to a ceiling-mounted AC outlet, as the weight

Preparation

of the adaptor may cause it to become disconnected.

- The unit will not work during a power failure. We recommend connecting a standard telephone to the same telephone line or to the same telephone socket using a telephone double adaptor.
- The unit is not designed to be used with rotary (pulse dialling) services.

If you subscribe to an ADSL service

- Please attach a noise filter (contact your ADSL provider) to the telephone line between the base unit and the telephone line socket in the event of the following:
 - Noise is heard during conversations.
 - Caller ID features (page 24) do not function properly.

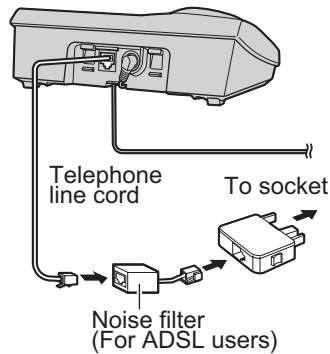

Location

- For maximum distance and noise-free operation, place your base unit:
 - away from electrical appliances such as TVs, radios, personal computers or other phones.
 - in a convenient, high and central location.

Battery installation/replacement

Important:

- Use only the included rechargeable batteries noted on page 4, 6.
- When replacing batteries, we recommend using the Panasonic rechargeable batteries noted on page 5, 6.

- 1 Press the notch on the handset cover firmly and slide it in the direction of the arrow.
 - When replacing batteries, remove the old batteries positive (+) terminal first.

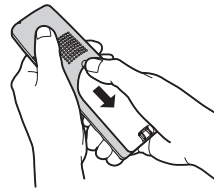

- 2 Insert the batteries negative (⊖) terminal first. Close the handset cover.

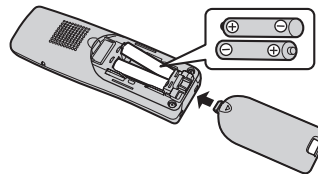

Battery charge

Place the handset on the base unit or charger for about 7 hours before initial use.

Preparation

When charging, the battery icon is shown as follows.



When the batteries are fully charged,  remains on the display.

- The charge indicator lights up when the handset is placed on the base unit or charger.

Base unit*1

Charger*2

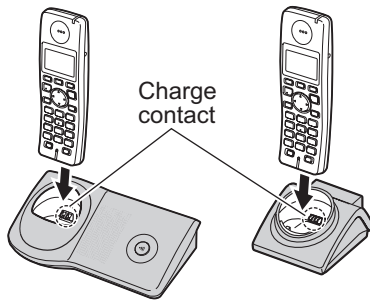



*1 The pictured model is KX-TG1831.

*2 KX-TG1837 only

Note:

- It is normal for the handset to feel warm during charging.
- If you want to use the unit immediately, charge the batteries for at least 15 minutes.
- Clean the charge contacts of the handset, base unit, and charger with a soft, dry cloth once a month, otherwise the batteries may not charge properly. Clean more often if the unit is exposed to grease, dust or high humidity.

Battery strength

Battery icon	Battery strength
	High
	Medium

Battery icon	Battery strength
	Low When flashing: Needs to be charged.

Panasonic Ni-MH battery performance (700 mAh)

Operation	Operating time
In continuous use	20 hours max.
In continuous standby mode	170 hours max.

Note:

- It is normal for batteries not to reach full capacity at the initial charge. Maximum battery performance is reached after a few complete cycles of charge/discharge (use).
- Actual battery performance depends on a combination of how often the handset is in use and how often it is not in use (standby).
- Battery operating time may be shortened over time depending on usage conditions and ambient temperature.
- Even after the handset is fully charged, the handset can be left on the base unit or charger without any ill effect on the batteries.
- The battery strength may not be displayed correctly after you replace the batteries. In this case, place the handset on the base unit or charger and charge for at least 7 hours.

Turning the power on/off

Power on

Press **[PWR]** for about 1 second.

Power off

Press **[PWR]** for about 2 seconds.

Preparation

Symbols used in these operating instructions

Symbol	Meaning
	Press .
→	Proceed to the next operation.
" "	Select the words in quotations shown on the display (e.g., "Handset Setup") by pressing or .

Display language

- 1
- 2 Press or to select "Handset Setup". →
- 3 Press or to select "Display Setup". →
- 4 Press or to select "Select Language". →
- 5 Press or to select the desired language. → →

Note:

- If you select a language you cannot read, press , press , press 3 times, press , press 2 times, press , press , press , select the desired language, press , then press .

Date and time

- 1
- 2 Press or to select "Handset Setup". →
- 3 Press or to select "Time Settings". → → Press or

to select "Set Date & Time". →

- 4 Enter the current day, month, and year.
Example: 17 May, 2006
- 5 Enter the current hour and minute.
Example: 3:30 PM
 → Press until "03:30 PM" is displayed.
- 6 →

Note:

- To correct a digit, press or to move the cursor, then make the correction.
- The date and time may be incorrect after a power failure. In this case, set the date and time again.

Making/Answering Calls

Making calls

- 1 Lift the handset and dial the phone number.
 - To correct a digit, press **[C/⊗]**, then enter the correct number.
- 2 **[↶]**
- 3 When finished talking, press **[⊗]** or place the handset on the base unit or charger.

Speakerphone

- 1 During a conversation, press **[⊗]** to turn on the speakerphone.
 - Speak alternately with the caller.
- 2 When finished talking, press **[⊗]**.

Note:

- For best performance, use the speakerphone in a quiet environment.
- To switch back to the receiver, press **[↶]**.

To adjust the receiver or speaker volume

Press **[▲]** or **[▼]** while on a call.

Redial feature

Previously dialled phone numbers (each 24 digits max.) can be redialled.

To make a call using the redial list

The last 10 phone numbers dialled are stored in the redial list.

- 1 **[⊙]**
- 2 Press **[▲]** or **[▼]** to select the desired number.
- 3 **[↶]** / **[⊗]**

To erase numbers in the redial list

- 1 **[⊙]**
- 2 Press **[▲]** or **[▼]** to select the desired number. → **[▶]**

- 3 “Erase” → **[▶]**

- 4 “Yes” → **[▶]** → **[⊗]**

Other features

Mute

While mute is turned on, you will be able to hear the other party, but the other party will not be able to hear you.

To mute your voice, press **[C/⊗]**.

- To return to the conversation, press **[C/⊗]** again.

R button (to use the recall feature)

[R] is used to access optional telephone services. Contact your service provider/telephone company for details.

Note:

- If your unit is connected to a PBX (private branch exchange), pressing **[R]** can allow you to access certain features of your host PBX such as transferring an extension call. Consult your PBX dealer for details.
- You can change the recall time (page 22).
- You can access your service provider/telephone company call waiting service by having the recall time set at 100 msec. (default setting, see page 22), and then follow your service provider/telephone company call waiting instructions to operate this service.

Pause button (for PBX/long distance service users)

A pause is sometimes required when making calls using a PBX or long distance service.

Example: If you have to dial **[0]** before dialling outside numbers manually, you will probably need to pause after dialling **[0]** until you hear a dial tone.

- 1 **[0]** → **[⊙]**
- 2 Dial the phone number. → **[↶]** / **[⊗]**

Making/Answering Calls

Note:

- A 3 second pause is inserted each time **[☎]** is pressed. Press repeatedly to insert longer pauses.

Answering calls

- 1 Lift the handset and press **[☎]** or **[📞]** when the unit rings.
 - You can also answer a call by pressing any dial key from **[0]** to **[9]**, **[*]**, **[#]**, or **[INT]**. (**Any key answer feature**)
- 2 When finished talking, press **[📞]** or place the handset on the base unit or charger.

Auto talk feature

You can answer calls simply by lifting the handset off the base unit or charger. You do not need to press **[☎]**. To turn this feature on, see page 19.

To adjust the ringer volume when an outside call is being received

Press **[▲]** or **[▼]**.

Handset locator

Using this feature, you can locate the handset if it has been misplaced.

- 1 Press **[📞]** on the base unit.
- 2 To stop paging, press **[📞]** on the base unit or press **[📞]** on the handset.

Phonebook

Handset phonebook

The handset phonebook allows you to make calls without having to dial manually. You can add 50 names and phone numbers to the handset phonebook and search for handset phonebook entries by name.

Adding entries to the handset phonebook

- 1 [] → []/OK
- 2 "New Entry" → [▶]
- 3 Enter the party's name (16 characters max.; page 42). → []/OK
- 4 Enter the party's phone number (24 digits max.). → []/OK
- 5 "Save" → [▶] → []

Finding and calling a handset phonebook entry

Handset phonebook entries can be searched for alphabetically, by first character or by scrolling through all handset phonebook entries.

When you have found the desired entry, press [].

Scrolling through all entries

- 1 []
- 2 Press [▲] or [▼] to display the desired entry.

Searching by first character (index search)

- 1 [] → [●]
- 2 Select the character entry mode that contains the character you are searching for. → [▶]

- 3 Press the dial key ([0] to [9]) which contains the character you are searching for (page 42).
 - Press the same dial key repeatedly to display the first entry corresponding to each letter located on that dial key.
 - If there is no entry corresponding to the letter you selected, the next entry will be displayed.
- 4 Press [▲] or [▼] to scroll through the phonebook if necessary.

Editing entries in the handset phonebook

Changing a name, phone number

- 1 Find the desired entry (page 17). → []/OK
- 2 "Edit" → [▶]
- 3 Edit the name if necessary (16 characters max.; page 42). → []/OK
- 4 Edit the phone number if necessary (24 digits max.). → []/OK
- 5 "Save" → [▶] → []

Erasing entries from the handset phonebook

Erasing an entry

- 1 Find the desired entry (page 17). → []/OK
- 2 "Erase" → [▶]
- 3 "Yes" → [▶] → []

Erasing all entries

- 1 [] → []/OK
- 2 "Erase All" → [▶]
- 3 "Yes" → [▶]
- 4 "Yes" → [▶] → []

Phonebook

Chain dial

This feature allows you to dial phone numbers in the handset phonebook while you are on a call. This feature can be used, for example, to dial a calling card access number or bank account PIN that you have stored in the handset phonebook, without having to dial manually.

- 1** While on a call, press [□□].
- 2** Press [▲] or [▼] to select the desired entry.
 - To search by first character (index search), see page 17.
- 3** Press [▶] to dial the number.

Handset Settings

Handset settings

- When customising the handset, the current item or setting is indicated by ►.

To customise the handset:

- 1 [☰/OK]
- 2 Press [▲] or [▼] to select "Handset Setup". → [►]
- 3 Press [▲] or [▼] to select the desired item in the handset settings menu. → [►]
- 4 Press [▲] or [▼] to select the desired item in the sub-menu. → [►]
- 5 Press [▲] or [▼] to select the desired setting then press [►] or follow the instruction in the "Feature" column of the chart.

- To exit the operation, press [✕⊙].

Handset settings menu	Sub-menu	Feature (default setting)
Time Settings	Set Date & Time	Date and time: page 14
	Alarm	Set the alarm: page 21
Ringer Setup	Ringer Volume	Handset ringer volume (<i>Maximum</i>) ^{*1}
	Ext. Ringtone	Ringtones for outside calls ("Ringtone 1") ^{*2}
	Int. Ringtone	Ringtones for intercom calls ("Ringtone 3") ^{*2}
Display Setup	Standby Display	Standby mode display ("Off") ^{*3}
	Select Language	Display language ("English"): page 14
	Contrast	Display contrast (<i>Level 3</i>)
Registration	Register H.set	page 37
Other Options	New Msg. Alert	New message alert ("Off") ^{*4}
	Keytones	Keytones on/off ("On")
	Auto Talk	Auto talk on/off ("Off") ^{*5}



Handset Settings



- *1 When the ringer is turned off, the handset will ring:
 - at the minimum level for alarm and intercom calls
 - at the maximum level for paging
- *2 If you select one of the melody ringtones, the ringtone will continue to sound for several seconds if the caller hangs up before you answer. You may hear a dial tone or no one on the line when you answer a call.
The preset melodies in this product are used with permission of © 2004 M-ZoNE Co., Ltd.
- *3 If “**Handset Number**” is selected and the current handset number is 2, “[2]” is displayed.
If “**OFF**” is selected, only current date and time are displayed.
- *4 This feature alerts you when new messages have been received or recorded:
 - SMS (page 28)
 - Answering system (page 32)The message indicator on the handset flashes until you have read or listened to all new messages.
While message alert is on, battery operating time is shortened (page 13).
- *5 Auto talk feature allows you to answer calls simply by lifting the handset off the base unit or charger. You do not need to press [↶].

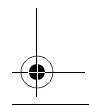
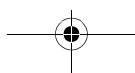
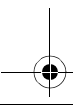
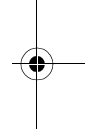
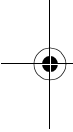

Time settings

Alarm

An alarm will sound for 3 minutes at the set time once or daily. Set the date and time beforehand (page 14).

- 1 **[☰/OK]** → “Handset Setup” → **[▶]**
- 2 “Time Settings” → **[▶]**
- 3 “Alarm” → Press **[▶]** 2 times.
- 4 Select an alarm mode. → **[▶]**

Off	Turns alarm off. Press [▶] again, then press [✕⊙] to finish.
Once	The alarm sounds once at the set time. Enter the desired day and month.
Daily	An alarm sounds daily at the set time.

- 5 Enter the desired hour and minute. → **[☰/OK]**
- 6 Select the desired ringtone. → **[▶]**
- 7 “Save” → **[▶]** → **[✕⊙]**

Note:

- To stop the alarm, press any dial key.
- When in talk or intercom mode, the alarm will not sound until the call has ended.
- If you select “Once”, the setting will change to “off” after the alarm sounds.

Base Unit Settings

Base unit settings

- Use the handset to customise the base unit.
- When customising the base unit, the current item or setting is indicated by ►.

To customise the base unit:

- 1 [≡/OK]
- 2 Press [▲] or [▼] to select “**Base Unit Setup**”. → [►]
- 3 Press [▲] or [▼] to select the desired item in the base unit settings menu. → [►]
- 4 Press [▲] or [▼] to select the desired item in the sub-menu. → [►]
- 5 Press [▲] or [▼] to select the desired setting then press [►] or follow the instruction in the “**Feature**” column of the chart.
 - To exit the operation, press [✕⊙].

Base unit settings menu	Sub-menu	Feature (default setting)
Ringer Volume	—	Base unit ringer volume (<i>Medium</i>)
Call Options	Recall/Flash	Change the recall time (“100 msec.”). ^{*1}
	Area Code	page 23
	Call Restrict	page 23
Other Options	Base Unit PIN	Change base unit PIN (“0000”). ^{*2} – Enter the current 4-digit base unit PIN. ^{*3} – Enter the new 4-digit base unit PIN. → [≡/OK]
	Repeater Mode	page 38

^{*1} Change the recall time, if necessary, depending on the requirements of your service provider/telephone company or PBX.

^{*2} If you change the PIN, please make note of your new PIN. The unit will not reveal the PIN to you.

^{*3} If you forget your PIN, see page 47.

Base Unit Settings

Call options

Selecting area codes to be deleted automatically

In some situations, phone numbers stored automatically in the Caller ID list (page 24) will include area codes. If you do not want to dial the area codes when making calls from the Caller ID list, you can store the area codes which you want the unit to delete automatically.

Example: You have stored the area code "123". If you make a call from the Caller ID list to the phone number "123-456-7890", the unit dials "456-7890".

- 1 **[≡/OK]** → "Base Unit Setup" → **[▶]**
- 2 "Call Options" → **[▶]**
- 3 "Area Code" → **[▶]**
- 4 Enter an area code (5 digits max.). → **[≡/OK]** → **[↶⊙]**

Setting call restriction

You can restrict selected handsets from dialling certain numbers. You can assign up to 6 phone numbers to be restricted, and select which handsets will be restricted. Storing area codes here will prevent the restricted handsets from dialling any phone number in that area code.

- 1 **[≡/OK]** → "Base Unit Setup" → **[▶]**
- 2 "Call Options" → **[▶]**
- 3 "Call Restrict" → **[▶]**
- 4 Enter the base unit PIN (default: "0000").
 - If you forget your PIN, see page 47.
- 5 Set which handsets will be restricted by pressing the desired handset number.

- All the registered handset numbers will be displayed.
- Flashing numbers indicate call restriction is turned on for the corresponding handset.
- To turn call restriction off for a handset, press the number again. The number will stop flashing.

- 6 **[≡/OK]**
- 7 Select a memory location. → **[▶]**
- 8 Enter the phone number or area code to be restricted (8 digits max.). → **[≡/OK]** → **[↶⊙]**
 - To erase a restricted number, press **[C/⊗]**.

Caller ID Service

Using Caller ID service

Important:

- This unit is Caller ID compatible. To use Caller ID features (such as displaying caller phone numbers), you must subscribe to Caller ID service. Consult your service provider/telephone company for details.

Caller ID features

When an outside call is received, the caller's phone number will be displayed.

- Phone numbers of the last 50 callers will be logged in the caller list.
- While listening to a message recorded by the answering system using the handset, you can call back the caller without having to dial the phone number (KX-TG1837 only; page 33).
- When caller information is received and it matches a phone number stored in the unit's phonebook, the stored name will be displayed and logged in the caller list.
- If the unit is connected to a PBX system, you may not receive the caller information.
- When the caller dialed from an area which does not provide Caller ID service, "Out of Area" will be displayed.
- When the caller requested not to send caller information, either no information or "Private Caller" will be displayed.

Missed calls

If a call is not answered, the unit treats the call as a missed call. The number of missed calls is shown on the display. This lets you know if you should view the caller list to see who called while you were out.

Call waiting and Caller ID compatible

If you subscribe to Caller ID service, your handset displays the 2nd caller's

information while talking. After you hear a call-waiting tone, the caller's phone number will be displayed.

You can answer the 2nd call, keeping the 1st call on hold. Follow your service provider/telephone company instructions using **[R]**.

- If the phone number is stored in the phonebook with its name, the caller's name will also be displayed.
- Please contact your service provider/telephone company for details and availability in your area.

For Caller ID type II users

When you receive a 2nd call during a conversation, you will hear a signal tone following the call waiting tone and the **conversation will be interrupted or muted for a short period of time**. This is not the fault of the product as these events are normal.

- The tones are generated by the service provider/telephone company.

Caller list

Viewing the caller list and calling back

- 1 **[≡/OK]** → "Caller List" → **[▶]**
- 2 Press **[▼]** to search from the most recent call, or press **[▲]** to search from the oldest call.
 - If the item has already been viewed or answered, "✓" is displayed, even if it was viewed or answered using another handset.
- 3 **[↶]** / **[☎]**

Note:

- If you do not want to dial the area codes when making calls from the Caller ID list, you can store the area codes which you

Caller ID Service

want the unit to delete automatically (page 23).

Editing a caller's phone number before calling back

- 1 **[☰/OK]** → "Caller List" → **[▶]**
- 2 Press **[▲]** or **[▼]** to display the desired entry.
- 3 **[☰/OK]** → "Edit and Call" → **[▶]**
- 4 Edit the number.
 - Press dial key (**[0]** to **[9]**) to add, **[C/⊗]** to delete.
- 5 **[↶] / [⏏]**

Erasing caller information

- 1 **[☰/OK]** → "Caller List" → **[▶]**
- 2 Press **[▲]** or **[▼]** to display the desired entry. → **[☰/OK]**
- 3 "Erase" → **[▶]**
 - To erase all entries, select "Erase All". → **[▶]**
- 4 "Yes" → **[▶]** → **[✕⓪]**

Storing caller information into the handset phonebook

- 1 **[☰/OK]** → "Caller List" → **[▶]**
- 2 Press **[▲]** or **[▼]** to display the desired entry. → **[☰/OK]**
- 3 "Add Phonebook" → **[▶]**
- 4 Continue from step 3, "Adding entries to the handset phonebook", page 17.

Voice mail service

Voice mail is an automatic answering service offered by your service provider/telephone company. If you

subscribe to this service, your service provider/telephone company's voice mail system will answer calls for you when you are unavailable to answer the phone or when your line is busy. Messages are recorded by your service provider/telephone company, not your telephone. Please consult your service provider/telephone company for details of this service.

Note:

- For more information on using the unit's answering system and your service provider/telephone company's voice mail service, see page 35. (KX-TG1837 only)

SMS (Short Message Service)

Using SMS (Short Message Service)

SMS allows you to send and receive text messages between other fixed-line and mobile phones that support compatible SMS networks and features.

Important:

- To use SMS features, you must:
 - subscribe to the Caller ID and/or appropriate service
 - confirm SMS is turned on
 - confirm the correct message centre numbers are stored

Consult your service provider/telephone company for details and availability.

If you have requested that your service provider/telephone company block your phone number when making phone calls, you will not be able to send SMS messages. In order to send messages, you need to add "1832" to the beginning of the Message Centre 1 number. Note that by doing so, your phone number will be sent along with your SMS messages.

Using the public mailbox and private mailboxes

SMS messages can be sent and received using the public mailbox or any one of the 6 private mailboxes. The public mailbox can be accessed freely. Private mailboxes are password protected to ensure privacy.

Important:

- To send or receive a message using a private mailbox, you must first create the private mailbox by storing its name and password (page 29)

Note:

- A total of 47 messages (at 160 characters/message) in all mailboxes added together can be saved. Total

number may be more than 47 if length of messages is less than 160 characters/message.

- If the unit is connected to a PBX system, you may not be able to use SMS features.

Turning SMS on/off

- 1 [≡/OK] → "SMS" → [▶]
- 2 "Public" → [▶]
- 3 "Settings" → [▶]
- 4 "SMS On/Off" → [▶]
- 5 "On" or "Off" → [▶] → [↵⊙]

Changing SMS message centre numbers

SMS message centre telephone numbers must be stored in order to send and receive SMS messages.

The message centre numbers (used for SMS services provided by Telstra) are preprogrammed in this unit. You can change them if necessary.

- Consult your service provider/telephone company for more information.

- 1 [≡/OK] → "SMS" → [▶]
- 2 "Public" → [▶]
- 3 "Settings" → [▶]
- 4 "Message Centre1" or "Message Centre2" → [▶]
- 5 Edit the number as necessary. → [≡/OK]
- 6 "Save" → [▶] → [↵⊙]







Note:

- If your phone is connected to a PBX, you need to add the PBX line access number and a dialling pause to the beginning of the Message Centre 1 phone number.

SMS (Short Message Service)

Sending a message

Writing and sending a new message

- 1 **[/OK]** → “SMS” → **[▶]**
- 2 **To access the public mailbox**
“Public” → **[▶]**
To access a private mailbox
Select the desired mailbox. → **[▶]** →
Enter its password.
- 3 “Create” → **[▶]**
- 4 Enter the message (page 42). →
[/OK]
- 5 Enter the destination phone number (20 digits max.). → **[/OK]**
 - Using the handset phonebook:
[] → Select the handset phonebook entry. → **[/OK]** 2 times
 - Using the caller list:
Press **[▲]** or **[▼]** to select the party.
→ **[/OK]** 2 times
 - Using the redial list:
Press **[●]** repeatedly to select the phone number. → **[/OK]** 2 times
 - If you wish to send the message to the other party's mailbox, enter the other party's mailbox number after the destination phone number.
Example: The other party's phone number is 123456 and their mailbox number is 1.
Enter 1234561.
- 6 To save the message, select “Yes”. → **[▶]**
- 7 To send the message, press **[▶]**.
 - To cancel sending, press **[✕⊙]**.



Note:

- This unit supports SMS messages of up to 612 characters, however, the maximum

number of characters you can send or receive may be limited by your SMS service provider/telephone company. Consult your SMS service provider/telephone company for details.

- If your message contains over 160 characters, the message is a long message and “**Long Message**” is displayed. Your service provider/telephone company may treat long messages differently from other messages. Consult your service provider/telephone company for details.
- If your phone is connected to a PBX, store the PBX line access number (page 30).

Sending a saved message

- 1 **[/OK]** → “SMS” → **[▶]**
- 2 **To access the public mailbox**
“Public” → **[▶]**
To access a private mailbox
Select the desired mailbox. → **[▶]** →
Enter its password.
- 3 “Send List” → **[▶]**
- 4 To read a saved message, press **[▲]** or **[▼]** to select the message. → **[/OK]**
- 5 To send the message, press **[/OK]**.
→ “Send” → **[▶]**
- 6 Press and hold **[C/⊗]** to erase all numbers, then continue from step 5, “Writing and sending a new message”, page 27.

Editing and sending a saved message

- 1 **[/OK]** → “SMS” → **[▶]**
- 2 **To access the public mailbox**
“Public” → **[▶]**
To access a private mailbox
Select the desired mailbox. → **[▶]** →
Enter its password.
- 3 “Send List” → **[▶]**

SMS (Short Message Service)

- 4 Press [▲] or [▼] to select the message.
→ [≡/OK]
- 5 [≡/OK] → "Edit Message" → [▶]
→ Continue from step 4, "Writing and sending a new message", page 27.

Erasing saved messages

- 1 [≡/OK] → "SMS" → [▶]
- 2 To access the public mailbox
"Public" → [▶]
To access a private mailbox
Select the desired mailbox. → [▶] →
Enter its password.
- 3 "Send List" → [▶]
- 4 Press [▲] or [▼] to select the message.
→ [≡/OK]
- 5 [≡/OK] → "Erase" → [▶]
 - To erase all messages in the selected mailbox, select "Erase All". → [▶]
- 6 "Yes" → [▶] → [↵]

Receiving a message

- When an SMS message is received:
- a tone is heard (if the handset ringer is turned on)
 - "Receiving SMS Message" is displayed
 - ☒ is displayed
 - the message indicator on the handset flashes if the message alert feature (page 19) has been turned on

Reading a received message

- 1 [≡/OK] → "SMS" → [▶]
- 2 To access the public mailbox
"Public" → [▶]
To access a private mailbox

Select the desired mailbox. → [▶] →
Enter its password.

- If a mailbox contains new (unread) SMS messages, "*" is displayed next to the total number of messages for that mailbox.

- 3 "Receive List" → [▶]
- 4 Press [▲] or [▼] to select a message.
 - Messages which have already been read are indicated by a "✓", even if they were read using another handset.
- 5 Press [≡/OK] to read the message content.

Note:

- To call the message sender, press [↵] or [☎].

Replying to a message

- 1 While reading a received message, press [≡/OK].
- 2 "Reply" → [▶]
- 3 Enter a message (page 42). → [≡/OK]
- 4 Edit the destination phone number and/or press [≡/OK].
- 5 Continue from step 6, "Writing and sending a new message", page 27.

Editing/forwarding a message

- 1 While reading a received message, press [≡/OK].
- 2 "Edit Message" → [▶]
- 3 Continue from step 6, "Writing and sending a new message", page 27.

Erasing received messages

- 1 While reading a received message, press [≡/OK].
- 2 "Erase" → [▶]

SMS (Short Message Service)

- To erase all messages in the selected mailbox, select **“Erase All”**. → [▶]

3 **“Yes”** → [▶] → [↵]

Storing the sender’s number in the handset phonebook

- 1 While reading a received message, press [≡/OK].
- 2 **“Add Phonebook”** → [▶]
- 3 Continue from step 3, **“Adding entries to the handset phonebook”**, page 17.

Editing the sender’s number before calling back

- 1 While reading a received message, press [≡/OK].
- 2 **“Edit and Call”** → [▶]
- 3 Edit the number. → [↶] / [↷]

SMS settings

SMS settings	Page
SMS on/off (default: “On”)	page 26
Message Centre 1	page 26
Message Centre 2	page 26
Private mailboxes (default: —)	page 29
PBX line access number (default: “off”)	page 30

Creating private mailboxes

Private mailboxes can be used for sending and receiving SMS messages. Each private mailbox is password protected.

- 1 [≡/OK] → **“SMS”** → [▶]
- 2 **“Public”** → [▶]
- 3 **“Settings”** → [▶]

4 **“Private Mailbox”** → [▶]

5 Select the desired new mailbox number (**“Mailbox1”** to **“Mailbox6”**). → [▶]

6 Enter a name for the mailbox (5 characters max.; page 42). → [≡/OK]

7 Enter a 4-digit password for the mailbox. → [≡/OK]

8 **“Save”** → [▶] → [↵]

Note:

- To receive SMS messages using a mailbox, inform others of your mailbox number.

Changing private mailbox settings

You can change the password or name of the private mailbox and erase the mailbox.

1 [≡/OK] → **“SMS”** → [▶]

2 **“Public”** → [▶]

3 **“Settings”** → [▶]

4 **“Private Mailbox”** → [▶]

5 Select the desired mailbox name. → [▶] 2 times

6 Enter the mailbox’s 4-digit password.

7 Edit the mailbox name (5 characters max.; page 42). → [≡/OK]

- To erase the mailbox, press and hold [C/✖]. → [≡/OK] → **“Yes”** → [▶] → [↵]

8 Enter a 4-digit password for the mailbox. → [≡/OK]

9 **“Save”** → [▶] → [↵]



Note:

- If you erase a mailbox, its messages will also be erased.

SMS (Short Message Service)

Storing the PBX line access number (for PBX users only)

Store your PBX line access number (4 digits max.) so that SMS messages are sent properly. When sending SMS messages to entries in the handset phonebook or redial list, the PBX line access number will be deleted.

- 1 **[/OK] → "SMS" → [▶]**
- 2 **"Public" → [▶]**
- 3 **"Settings" → [▶]**
- 4 **"PBX Access No." → [▶]**
- 5 **"On" → [▶]**
- 6 Enter your PBX line access code and a dialling pause, if necessary. → **[/OK]**
- 7 **"Save" → [▶] → [⊙]**

Answering System Features (KX-TG1837 only)

Answering system

The KX-TG1837 contains an answering system which can answer and record calls for you when you are unavailable to answer the phone.

Important:

- Only 1 person can access the answering system (listen to messages, record a greeting message, etc.) at a time.
- When callers leave messages, the unit records the day and time of each message. Make sure the date and time have been set (page 14).

Memory capacity

The total recording capacity (including your greeting message and caller messages) is about 20 minutes. A maximum of 64 messages can be recorded.

Note:

- If message memory becomes full, answer on indicator on the base unit flashes rapidly.

Turning the answering system on/off

Using the base unit

Press **[OK]** to turn on/off the answering system.

- When the answering system is turned on, the answer on indicator lights up.

Using the handset

- 1 **[OK]** → "Answer System" → **[▶]**
- 2 "Answer On" or "Answer Off" → **[▶]** → **[*0]**

Note:

- When the answering system is turned on, **[OK]** is displayed.

Greeting message

When the unit answers a call, callers are greeted by a greeting message. You can record your own greeting message or use a prerecorded greeting message.

Recording a greeting message

You can record your own greeting message (2 minutes and 30 seconds max.).

- 1 **[OK]** → "Answer System" → **[▶]**
- 2 "Record Greeting" → **[▶]**
 - Hold the handset about 20 cm away and speak clearly into the microphone.
- 3 Press **[OK]** to stop recording. → **[*0]**

Using a prerecorded greeting message

If you erase or do not record your own greeting message, the unit will play a prerecorded greeting message for callers and ask them to leave messages. If the message recording time (page 35) is set to "Greeting Only", caller messages will not be recorded and the unit will play a different prerecorded greeting message asking callers to call again.

Playing back the greeting message

- 1 **[OK]** → "Answer System" → **[▶]**
- 2 "Play Greeting" → **[▶]** → **[*0]**

Answering System Features (KX-TG1837 only)

Erasing the greeting message

If you erase your own greeting message, the unit will play a prerecorded greeting message for callers.

- 1 **[M]/OK** → “Answer System” → **[▶]**
- 2 “Erase Message” → **[▶]**
- 3 “Erase Greeting” → **[▶]**
- 4 “Yes” → **[▶]** → **[*]0**

Listening to messages

Messages are stored and played back chronologically, from oldest message to newest.

Listening to new/all messages

When you have new messages:

- **[▶]** on the base unit flashes
- the message indicator on the handset flashes if the message alert feature (page 19) has been turned on

Note:

- To adjust the speaker volume during playback, press **[▲]** or **[▼]**.

Using the base unit

[▶]

- If new messages have been recorded, the base unit plays back new messages.
- If there are no new messages, the base unit plays back all messages.

Note:

- After playing back all of the new messages, **[▶]** will stop flashing but the answer on indicator will remain lit up when the answering system is turned on.

Using the handset

- 1 **[M]/OK** → “Answer System” → **[▶]**
- 2 “Play New Msg.” or “Play All Msg.” → **[▶]**

Repeating, skipping, stopping, erasing a message during playback

- To repeat a message during playback:
 - for the base unit, press **[◀◀]**
 - for the handset, press **[◀]**
 If pressed within the first 5 seconds of a message, the previous message will be played.
- To skip a message during playback:
 - for the base unit, press **[▶▶]**
 - for the handset, press **[▶]**
- To stop a message during playback:
 - for the base unit, press **[■]**
 - for the handset, press **[9]**
- To erase a message during playback:
 - for the base unit, press **[X]**
 - for the handset, press **[*]4**

Erasing all messages

Using the base unit

[X] 2 times

Using the handset

- 1 **[M]/OK** → “Answer System” → **[▶]**
- 2 “Erase Message” → **[▶]**
- 3 “Erase All” → **[▶]**
- 4 “Yes” → **[▶]** → **[*]0**

Answering System Features (KX-TG1837 only)

Calling back (Caller ID subscribers only)

If caller information was received for the call, you can call the caller back while listening to a message.

- 1 Press **[END/OK]** during playback.
- 2 "Call Back" → **[▶]**

Note:

- To edit the number before calling back, select "Edit and Call". → **[▶]** → Edit the number. → **[↶]** / **[↷]**

Direct command operation using the handset

You can operate the answering system by pressing dial keys, rather than navigating through the menus. To use the following commands, press **[END/OK]**. → "Answer System" → **[▶]**

Key	Direct commands
[1]	Repeat message (during playback)*1
[2]	Skip message (during playback)
[3]	Enter the "Settings" menu
[4]	Play new messages
[5]	Play all messages
[6]	Play greeting message
[7][6]	Record greeting message
[8]	Turn answering system on
[9]	Stop (recording, playback)
[0]	Turn answering system off
[*][4]	Erase this message (during playback)
[*][5]	Erase all messages

Key	Direct commands
[*][6]	Erase greeting message

*1 If pressed within the first 5 seconds of a message, the previous message will be played.

Remote operation

Using a touch tone phone, you can call your phone number from outside and access the unit to listen to messages or change answering system settings. The unit's voice guidance will prompt you to press certain dial keys to perform different operations.

Important:

- In order to operate the answering system remotely, you must first turn on remote operation by setting a remote access code. This code must be entered each time you operate the answering system remotely.

Turning remote operation on

A 3-digit remote access code must be entered when operating the answering system remotely. This code prevents unauthorised parties from listening to your messages remotely. After you store your remote access code, remote operation is possible.

- 1 **[END/OK]** → "Answer System" → **[▶]**
- 2 "Settings" → **[▶]**
- 3 "Remote Code" → **[▶]**
- 4 To turn on remote operation, enter a 3-digit remote access code.
 - To turn off remote operation, press **[*]**.
- 5 **[END/OK]** → **[*][0]**

Answering System Features (KX-TG1837 only)

Note:

- If you have stored the remote access code, you can turn on answering system by calling the unit even when it is turned off.

Using the answering system remotely

- 1 Dial your phone number from a touch tone phone.
- 2 After the greeting message starts, enter your remote access code.
 - The unit will announce the number of new messages.
 - After 3 seconds, voice guidance starts.
- 3 Follow the voice guidance prompts as necessary.

Note:

- You can hang up at any time.
- You can ignore the voice guidance and control the unit using remote commands (page 34).

Voice guidance

During remote operation, the unit's voice guidance will prompt you to press **[1]** to perform a specific operation, or press **[2]** to listen to more available operations.

Note:

- If less than 5 minutes of recording time is available, the unit will announce the remaining recording time after the last message is played back.

Remote commands

You can press dial keys to access certain answering system functions without waiting for the voice guidance to prompt you.

Key	Remote command
[1]	Repeat message (during playback) ^{*1}
[2]	Skip message (during playback)
[4]	Play new messages
[5]	Play all messages
[6]	Play greeting message
[7]	Record greeting message
[9]	Stop (recording, playback)
[0]	Turn answering system off
[*][4]	Erase this message (during playback)
[*][5]	Erase all messages
[*][6]	Erase greeting message (during greeting message playback)
[*][#]	End remote operation (or hang up)

*1 If pressed within the first 5 seconds of a message, the previous message will be played.

Turning on the answering system remotely

If the answering system is off, you can turn it on remotely.

- 1 Dial your phone number from a touch tone phone.
- 2 Let the phone ring 15 times.
 - A long beep will be heard.
- 3 Enter your remote access code within 10 seconds after the long beep.

Answering System Features (KX-TG1837 only)

- The greeting message is played back.
- You can hang up, or enter your remote access code again and begin remote operation.

Answering system setting

Answering system setting	Default setting	Page
Answering system on/off	Answer On	page 31
Remote access code	—	page 33
Number of rings	4 Rings	page 35
Caller's recording time	3 Minutes	page 35
Call screening	On	page 36

Changing the number of rings

You can change the number of times the phone rings before the unit answers calls. You can select 2 to 7 rings, or "Auto". "Auto": The unit answers after 2 rings when new messages have been recorded, and after 5 rings when there are no new messages. If you call your phone from outside to listen to new messages (page 34), you will know that there are no new messages when the phone rings for the 3rd time. You can then hang up without being charged for the call.

- 1 **[☰/OK]** → "Answer System" → **[▶]**
- 2 "Settings" → **[▶]**
- 3 "Number of Rings" → **[▶]**
- 4 Select the desired setting. → **[▶]** → **[*0]**

For Telstra Homeline service subscribers

To receive Voice Mail and use answering system properly, please note the following:

- "Voice Mail" is a service provided by your Service Provider. You will need to first subscribe or activate this service through your Service Provider. Consult your Service Provider on how to operate this service and how you will be notified that you have messages on your Voice Mail.

To use this service you will be required to leave your answering machine off on your unit.

This will allow the Voice Mail to receive any messages.

This unit does not have a visual indicator to indicate if there are new messages in your Voice Mail service. Your Service Provider may use a "Stutter" dial tone to indicate that you have Voice Mail left.

- To use the unit's answering machine rather than the Voice Mail service provided by your Service Provider, please consult your Service Provider to have it removed or deactivated permanently or temporarily.

Alternatively you can leave this service connected and change the "Ring count" to a shorter duration on your unit so your unit's answering machine can pick up the call prior to the Voice Mail provided by your Service Provider.

Note:

- Provider Voice Mail can capture messages that can be missed while the customer is on the Internet.

Selecting the caller's recording time

You can change the maximum message recording time allotted to each caller, or set the unit to greet callers but not record messages.

Answering System Features (KX-TG1837 only)

- 1 **[☰/OK]** → “Answer System” → **[▶]**
- 2 “Settings” → **[▶]**
- 3 “Recording Time” → **[▶]**
- 4 Select the desired setting. → **[▶]** → **[↻⊙]**

Turning call screening on/off

While a caller is leaving a message, you can screen the call through the handset speaker.

- 1 **[☰/OK]** → “Answer System” → **[▶]**
- 2 “Settings” → **[▶]**
- 3 “Call Screening” → **[▶]**
- 4 “On” or “Off” → **[▶]** → **[↻⊙]**

Multi-unit Operation

Operating additional units

Additional handsets

Up to 6 handsets can be registered to the base unit. Additional handsets will give you the freedom to, for example, have an intercom call with another handset while a third handset is on an outside call. See page 5 for information on ordering additional handsets.

Important:

- The additional handset model recommended for use with this unit is noted on page 5. If other model handset is used, certain operations (handset settings, base unit settings, etc.) may not be available.

Registering a handset to the base unit

The included handset and base unit are preregistered. If for some reason the handset is not registered to the base unit (for example, Ψ flashes even when the handset is near the base unit), register the handset manually (page 37).

To register an additional handset to the base unit (easy registration)

After purchasing an additional handset, register it to the base unit. Ensure that the additional handset is switched on. If it is not on, press and hold Ψ for few seconds to turn the handset on.

- 1 Lift the additional handset and press Ψ to put the handset in standby mode.
- 2 Press and hold Ψ on the base unit for about 3 seconds, until the registration tone sounds.

- 3 Place the additional handset on the base unit. The registration tone continues to sound. With the handset still on the base unit, wait until a confirmation tone sounds and Ψ stops flashing.

Note:

- If an error tone sounds, or if Ψ is still flashing, register the handset manually (manual registration; page 37).
- If all registered handsets start ringing in step 2, press Ψ to stop. Start again from step 1.
- Charge the batteries of your additional handset for about 7 hours before initial use.
- This registration method cannot be used for handsets that have already been registered to the base unit. Register the handset manually (manual registration; page 37).

To register a handset to the base unit (manual registration)

You can register a handset to the base unit manually using the following method.

- 1 Ψ / OK \rightarrow "Handset Setup" \rightarrow Ψ
- 2 "Registration" \rightarrow Ψ
- 3 "Register H.set" \rightarrow Ψ
- 4 Press and hold Ψ on the base unit for about 3 seconds, until the registration tone sounds.
 - If all registered handsets start ringing, press Ψ to stop, then repeat this step.
 - After pressing Ψ , the rest of this procedure must be completed within 1 minute.
- 5 Wait until "Enter Base PIN" is displayed, then enter the base unit PIN (default: "0000"), then press Ψ / OK.
 - If you forget your PIN, see page 47.

Multi-unit Operation

- When the handset has been registered successfully, Ψ will stop flashing. If keytones are turned on (page 19), a confirmation tone will be heard.

Cancelling a handset

A maximum of 6 handsets can be registered to the base unit. A handset can cancel its own registration (or the registration of another handset) that is stored in the base unit. This will allow the base unit to “forget” the handset.

- 1 **[\square /OK]** → “Base Unit Setup” → **[▶]**
- 2 Enter “335”.
- 3 “Cancel Handset” → **[▶]**
 - The numbers of all handsets registered to the base unit are displayed.
- 4 Select the handset(s) you want to cancel, by pressing the desired handset number. → **[\square /OK]**
 - The selected handset number(s) will flash.
 - To cancel a selected handset number, press the number again. The number will stop flashing.
- 5 “Yes” → **[▶]** → **[Ψ]**

Increasing the range of the base unit

You can increase the range of the base unit by using a DECT repeater. Please use only the Panasonic DECT repeater noted on page 5. Consult your Panasonic dealer for details.

Important:

- Before registering the repeater to this base unit, you must turn the repeater mode on.

Setting the repeater mode

- 1 **[\square /OK]** → “Base Unit Setup” → **[▶]**
- 2 “Other Options” → **[▶]**
- 3 “Repeater Mode” → **[▶]**
- 4 “On” or “Off” → **[▶]** → **[Ψ]**

Note:

- After turning repeater mode on or off, Ψ will flash on the handset momentarily. This is normal. The handset can be used once Ψ stops flashing.

Intercom between handsets

Intercom calls can be made between handsets in the same radio cell.

Example: When handset 1 calls handset 2

- 1 **Handset 1:**
[INT] → Press **[2]** (desired handset number).
- 2 **Handset 2:**
Press **[Ψ]** / **[Ψ]** to answer.
- 3 When finished talking, press **[Ψ]**.

Transferring calls between handsets, conference calls

Example: When handset 1 transfers a call to handset 2

Transferring calls between handsets

Outside calls can be transferred between 2 people in the same radio cell.

- 1 **Handset 1:**

Multi-unit Operation

During an outside call, press **[INT]**. →
Press **[2]** (desired handset number).

- The outside call will be put on hold.
- If there is no answer, press **[INT]** to return to the outside call.

- 2 Handset 2:**
Press **[↶]** / **[↷]** to answer the page.
 - Handset 2 can talk with handset 1.
- 3 Handset 1:**
To complete the call transfer, press **[↶⊙]**.



Conference calls (~~KX-TG7120, KX-TG7122, and KX-TG7123 only~~)

2 people in the same radio cell can have a conference call with an outside party.

- 1 Handset 1:**
During an outside call, press **[INT]**. →
Press **[2]** (desired handset number).
 - The outside call will be put on hold.
 - If there is no answer, press **[INT]** to return to the outside call.
- 2 Handset 2:**
Press **[↶]** / **[↷]** to answer the page.
 - Handset 2 can talk with handset 1.
- 3 Handset 1:**
To establish a conference call, press **[3]**.

Transferring a call without speaking to the other handset user

- 1** During an outside call, press **[INT]**. →
Press the desired handset number.
 - flashes to indicate the outside call is on hold.
- 2 [↶⊙]**
 - The outside call rings at the other handset.

Note:

- If the other handset user does not answer the call within 1 minute, the call will ring at your handset again.

Copying phonebook entries

You can copy handset phonebook entries to the handset phonebook of another compatible Panasonic handset.

Copying one entry

- 1** Find the desired handset phonebook entry (page 17). → **[≡/OK]**
- 2** "Copy" → **[▶]**
- 3** Enter the handset number you wish to send the handset phonebook entry to.
- 4** To continue copying another entry: "Yes" → **[▶]** → Find the desired handset phonebook entry. → **[▶]**
- 5** **[↶⊙]**

Copying all entries

- 1** **[□□]** → **[≡/OK]**
- 2** "Copy All" → **[▶]**
- 3** Enter the handset number you wish to send the handset phonebook entry to.
- 4** **[↶⊙]**

Useful Information

Wall-mounting

Note:

- Be sure to choose a location close enough to connect the telephone line cord and AC adaptor securely.

Base unit

- 1 Tuck the telephone line cord inside the wall-mounting adaptor (1). Connect the telephone line cord (2).

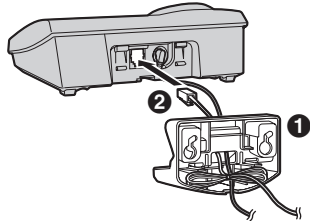

- 2 Insert the hooks on the wall-mounting adaptor into the holes (A) and (B) on the base unit.

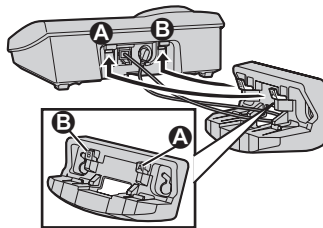

- 3 Adjust the adaptor to hold the base unit, then push it in the direction of the arrow until it clicks into place.

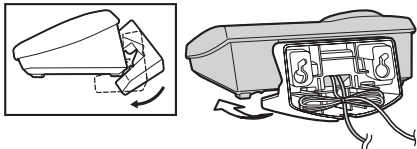

- 4 Drive the screws into the wall. Make sure to use the template for correct positioning. Mount the unit by inserting the screws into the round openings on the adaptor, then sliding the unit down to secure it. Connect the AC adaptor to power outlet (page 11) and the telephone line cord to the telephone line jack.

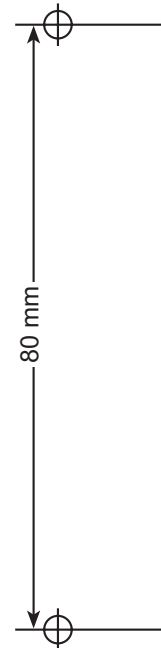
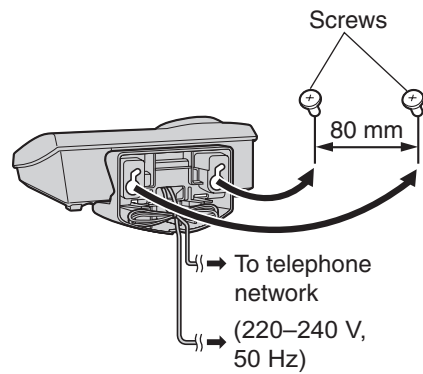

Useful Information

To remove the wall-mounting adaptor

While pushing down the release levers (❶), remove the adaptor (❷).

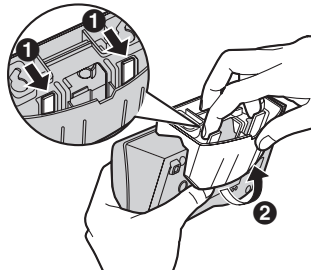

Charger (KX-TG1837 only)

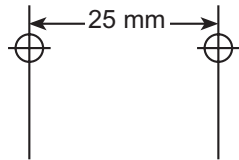
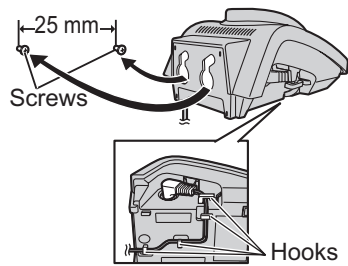

Using an optional belt clip

Attaching the belt clip

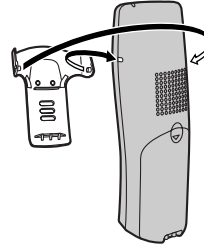

Removing the belt clip



Useful Information

Character entry

The dial keys are used to enter characters and numbers. Each dial key has multiple characters assigned to it. The available character entry modes are Alphabet (ABC), Numeric (0-9), Greek (ABΓ), Extended 1 (AÄÅ), Extended 2 (ŠŠŠ), and Cyrillic (АБВ). For SMS messages, Alphabet (ABC), Numeric (0-9), Greek (ABΓ), and Extended (AÄÅ) modes are available. When in these entry modes except Numeric, you can select which character is entered by pressing a dial key repeatedly.

- Press [◀] or [▶] to move the cursor.
- Press dial keys to enter characters and numbers.
- Press [C/⌫] to erase the character or number highlighted by the cursor. Press and hold [C/⌫] to erase all characters or numbers.
- Press [↵] to switch between uppercase and lowercase.
- To enter another character located on the same dial key, press [▶] to move the cursor to the next space, then press the appropriate dial key.

Character entry modes

Several character entry modes can be used when entering text. The characters that can be entered depend on the entry mode.

Characters available in each character entry mode

When the unit displays the character entry screen:

[□] → Select a character entry mode. → [▶]

Note:

- For character entry when writing SMS messages, see page 44.

Alphabet character table (ABC)

0	1	ABC 2	DEF 3	GHI 4	JKL 5	MNO 6	PQRS 7	TUV 8	WXYZ 9
Space	Space #	A B C	D E F	G H I	J K L	M N O	P Q R S	T U V	W X Y Z
0	& ' () *	2	3	4	5	6	7	8	9
	, - . / 1	a b c	d e f	g h i	j k l	m n o	p q r s	t u v	w x y z
		2	3	4	5	6	7	8	9

Numeric entry table (0-9)

0	1	ABC 2	DEF 3	GHI 4	JKL 5	MNO 6	PQRS 7	TUV 8	WXYZ 9
0	1	2	3	4	5	6	7	8	9

Useful Information

Greek character table (ΑΒΓ)

0	1	ABC2	DEF3	GHI4	JKL5	MNO6	PQRS7	TUV8	WXYZ9
Space 0	Space # & ' () * , - . / 1	A B Γ 2	Δ E Z 3	H Θ I 4	K Λ M 5	N Ξ O 6	Π P Σ 7	T Υ Φ 8	X Ψ Ω Ξ 9

Extended 1 character table (ΑĂĂ)

0	1	ABC2	DEF3	GHI4	JKL5	MNO6	PQRS7	TUV8	WXYZ9
Space 0	Space # & ' () * , - . / 1	A Ă Ą Ă Ă Ą Ă Æ B C Ç 2	D Ę Ę É Ê Ę Ë F 3	G Ğ H I Ĩ Ĩ Ī Ī Ī 4	J K L 5	M N Ń O Ő Ó ø 6	P Q R S Ş B 7	T U Ū Ú Ū Ū Û V 8	W Ŵ X Y ŷ Z 9
		a ă ą â ă ą à æ b ç 2	d ę ę é ê ę ë f 3	g ǵ h i ĩ ĩ ī ī ī 4	j k l 5	m n ń o ő ó ø 6	p q r s ş B 7	t u ū ú ū ū û v 8	w ŵ x y ŷ z 9

- The following are used for both uppercase and lowercase: ø Ş Ŵ ŷ

Extended 2 character table (ŠŚŠ)

0	1	ABC2	DEF3	GHI4	JKL5	MNO6	PQRS7	TUV8	WXYZ9
Space 0	Space # & ' () * , - . / 1	A Ā Ā Ą Ą Ą Ĉ ĉ 2	D Ď Ď É Ě Ě F 3	G Ħ I Í 4	J K L Ł ł Ł 5	M N Ń Ń Ő Ó ø 6	P Q R Š Ř Š Š Š 7	T Ť U Ú Ū Ū Û V 8	W X Y ŷ Ź Ž Ž 9
		a ā ą Ą ą ą Ĉ ĉ 2	d ď ę é ě ě f 3	g ħ i Í 4	j k l Ł ł Ł 5	m n ń ň ő ó ø 6	p q r Š ř š š š 7	t ť u ú ū ū û v 8	w x y ŷ ź ž ž 9

- The following are used for both uppercase and lowercase:

Ą Ć Ć Ę Ł ł Ń Ń Š š ŷ Ź ž Ž

Cyrillic character table (АБВ)

0	1	ABC2	DEF3	GHI4	JKL5	MNO6	PQRS7	TUV8	WXYZ9
Space 0	Space # & ' () * , - . / 1	А Б В Г 2	Д Е Ж З 3	И Й К Л 4	М Н О П 5	Р С Т У 6	Ф Х Ц Ч 7	Ш Щ Ъ Ъ 8	Ь Э Ю Я 9

Useful Information

When writing SMS messages

Alphabet character table (ABC)

0	1	ABC 2	DEF 3	GHI 4	JKL 5	MNO 6	PQRS 7	TUV 8	WXYZ 9
Space 0	Space . @ / : ; * # + - 1 " ' , ! ; ? ¿ - € £ \$ ¥ () [] { } & % \ ^ ~ < > = □ §	A B C 2	D E F 3	G H I 4	J K L 5	M N O 6	P Q R S 7	T U V 8	W X Y Z 9
		a b c 2	d e f 3	g h i 4	j k l 5	m n o 6	p q r s 7	t u v 8	w x y z 9

Numeric entry table (0-9)

0	1	ABC 2	DEF 3	GHI 4	JKL 5	MNO 6	PQRS 7	TUV 8	WXYZ 9
0	1	2	3	4	5	6	7	8	9

Greek character table (ABΓ)

0	1	ABC 2	DEF 3	GHI 4	JKL 5	MNO 6	PQRS 7	TUV 8	WXYZ 9
Space 0	Space . @ / : ; * # + - 1 " ' , ! ; ? ¿ - € £ \$ ¥ () [] { } & % \ ^ ~ < > = □ §	A B Γ 2	Δ E Z 3	H Θ I 4	K Λ M 5	N Ξ O 6	Π Ρ Σ 7	T Υ Φ 8	X Ψ Ω 9

Extended character table (AÄÅ)

0	1	ABC 2	DEF 3	GHI 4	JKL 5	MNO 6	PQRS 7	TUV 8	WXYZ 9
Space 0	Space . @ / : ; * # + - 1 " ' , ! ; ? ¿ - € £ \$ ¥ () [] { } & % \ ^ ~ < > = □ §	A Ä Á 2	D E È 3	G Ğ 4	J K L 5	M N Ñ 6	P Q R S 7	T U Û 8	W X Y Z 9
		À Á Â 2	É Ê Ë 3	Ħ Ĩ Ī 4		Ō Ő Œ 6	Š Ÿ 7	Ú Û Ü 8	Ý Þ 9
		a à á 2	d e è 3	g ğ h 4	j k l 5	m n ñ 6	p q r s 7	t u ù 8	w x y z 9
		â ã ä 2	é ê ë 3	ï ï ï ï 4		ó ô ö 6	ß 7	ú û ü 8	ý þ 9
		å æ b 2	ë f 3	ĥ ĭ ĵ 4		ø ö ø 6		ü v 8	
		c ç 2							

- The following are used for both uppercase and lowercase: ø Š

Useful Information

Error messages

Error message	Cause & solution
Answer Sys. Full* ¹	<ul style="list-style-type: none"> ● Erase unnecessary messages (page 32).
Error* ¹	<ul style="list-style-type: none"> ● Recording was too short. Try again.
Failed	<ul style="list-style-type: none"> ● Phonebook copy failed. Confirm the other handset (the receiver) is in standby mode and try again.
Incomplete	<ul style="list-style-type: none"> ● There was an error while copying phonebook entries. Erase the unnecessary phonebook entries from the other handset (the receiver) and try again.
Invalid Number	<ul style="list-style-type: none"> ● You tried to send an SMS message to a phone number saved in the handset phonebook, caller list, or redial list that is over 20 digits long.
Memory Full	<ul style="list-style-type: none"> ● The handset's phonebook memory is full. Erase unnecessary entries (page 17). ● Message memory becomes full. Erase unnecessary messages (page 32).
SMS Full	<ul style="list-style-type: none"> ● Erase unnecessary messages (page 28, 28).
You must first subscribe to Caller ID.	<ul style="list-style-type: none"> ● You must subscribe to Caller ID service. Once you receive caller information after subscribing to Caller ID service, this message will not be displayed.

*1 KX-TG1837 only

Troubleshooting

If you still have difficulties after following the instructions in this section, disconnect the AC adaptor and turn off the handset, then reconnect the AC adaptor and turn on the handset.

Telephone

Problem	Cause & solution
Y is flashing.	<ul style="list-style-type: none"> ● The handset is not registered to the base unit. Register it (page 37). ● The handset is too far from the base unit. Move closer. ● The AC adaptor is not connected. Check the connections. ● You are using the handset or base unit in an area with high electrical interference. Place the handset and base unit away from interference sources, such as antennas and mobile phones.

Useful Information

Problem	Cause & solution
The handset display is blank.	<ul style="list-style-type: none"> • The handset is not turned on. Turn the power on (page 13).
The handset will not turn on.	<ul style="list-style-type: none"> • Make sure that the batteries are installed correctly (page 12). • Fully charge the batteries (page 12). • Clean the charge contacts and charge again (page 12).
I have changed the display language to a language I cannot read.	<ul style="list-style-type: none"> • Change the display language (page 14).
I cannot make or receive calls.	<ul style="list-style-type: none"> • The AC adaptor or telephone line cord is not connected. Check the connections. • If you are using a splitter to connect the unit, remove the splitter and connect the unit to the wall socket directly. If the unit operates properly, check the splitter. • Disconnect the base unit from the telephone line and connect the line to a known working telephone. If the working telephone operates properly, contact our service personnel to have the unit repaired. If the working telephone does not operate properly, contact your service provider/telephone company. • You dialled a call restricted number (page 23). • The unit is not designed to be used with rotary (pulse dialling) services.
The unit does not ring.	<ul style="list-style-type: none"> • The ringer volume is turned off. Adjust the ringer volume (page 19, 22).
The batteries should be charging but the battery icon does not change.	<ul style="list-style-type: none"> • Clean the charge contacts and charge again (page 12).
A busy tone is heard when  is pressed.	<ul style="list-style-type: none"> • The handset is too far from the base unit. Move closer and try again. • Another handset is on an outside call. Wait for the other user to complete the call.
Static is heard, sound cuts in and out. Interference from other electrical units.	<ul style="list-style-type: none"> • Place the handset and the base unit away from other electrical appliances. • Move closer to the base unit. • Your unit is connected to a telephone line with ADSL service. We recommend connecting a filter (contact your ADSL service provider) to the telephone line between the base unit and the telephone line socket.

Useful Information

Problem	Cause & solution
Noise is heard during a call.	<ul style="list-style-type: none"> You are using the handset or base unit in an area with high electrical interference. Place the handset and base unit away from interference sources, such as antennas and mobile phones.
The handset/base unit stops working while being used.	<ul style="list-style-type: none"> Disconnect the AC adaptor and turn off the handset. Connect the AC adaptor, turn on the handset and try again.
Pressing [OK] does not display/dial the last number dialled.	<ul style="list-style-type: none"> The redialled number was more than 24 digits long. Redial the number manually.
The handset beeps intermittently and/or [BATT] flashes.	<ul style="list-style-type: none"> Fully charge the batteries (page 12).
I fully charged the batteries, but [BATT] still flashes.	<ul style="list-style-type: none"> Clean the charge contacts and charge again (page 12). It is time to replace the batteries (page 12).
Caller information is not displayed.	<ul style="list-style-type: none"> You must subscribe to Caller ID service. Your unit is connected to a telephone line with ADSL service. We recommend connecting a filter (contact your ADSL service provider) to the telephone line between the base unit and the telephone line socket. Caller has withheld information.
While viewing caller information, the display returns to standby mode.	<ul style="list-style-type: none"> Do not pause for over 1 minute while searching.
I cannot register a handset to the base unit.	<ul style="list-style-type: none"> The maximum number of handsets (6) are already registered to the base unit. Cancel unused handset registrations from the base unit (page 38). You entered the wrong PIN number. If you forget your PIN, see "I cannot remember the PIN." below. Place the handset and the base unit away from other electrical appliances.
I cannot remember the PIN.	<ul style="list-style-type: none"> Change the PIN using the following method. <ol style="list-style-type: none"> [MENU/OK] Press [▲] or [▼] to select "Base Unit Setup". → [▶] "Other Options" → [▶] "Base Unit PIN" → [▶] Press [*][7][0][0][0]. Enter the new 4-digit base unit PIN. → [▶] → [*][0]

Useful Information

SMS (Short Message Service)

Problem	Cause & solution
I cannot send or receive SMS messages.	<ul style="list-style-type: none"> You have not subscribed to the appropriate service. Consult your service provider/telephone company. The SMS message centre number(s) are not stored or are incorrect. Store the correct numbers (page 26). You may request that your service provider/telephone company block your phone number when making phone calls. In order to send messages, you need to add "1832" to the beginning of the Message Centre 1 number (page 26). Note that by doing so, your phone number will be sent along with your SMS messages. Message transmission was interrupted. Wait until the message has been sent before using other telephone functions. Your unit is connected to a telephone line with ADSL service. We recommend connecting a filter (contact your ADSL service provider) to the telephone line between the base unit and the telephone line socket.
The SMS message centre number is logged in the caller list and the message is not received.	<ul style="list-style-type: none"> Someone tried to send you a message while SMS is turned off.
"FD" is displayed.	<ul style="list-style-type: none"> The unit could not connect to the SMS message centre. Confirm that the correct SMS message centre numbers are stored (page 26). Confirm that SMS is turned on (page 26).
"FE" is displayed.	<ul style="list-style-type: none"> An error occurred while sending the message. Try again.
"E0" is displayed.	<ul style="list-style-type: none"> Your phone number is permanently withheld or you have not subscribed to the appropriate service. Consult your service provider/telephone company.
"√" is not displayed after I read a message.	<ul style="list-style-type: none"> When an error code ("FD", "FE", or "E0") is displayed, "√" will not be displayed even if you have read the message.

Useful Information**Answering system (KX-TG1837 only)**

Problem	Cause & solution
The unit does not record new messages.	<ul style="list-style-type: none"> • The answering system is turned off. Turn it on (page 31). • The recording time is set to "Greeting Only". Select "1 Minute" or "3 Minutes" (page 35). • If you subscribe to the voice mail service, messages are recorded by your service provider/telephone company not your telephone. Change the unit's "Number of Rings" setting so that the unit's answering system can answer the call before the voice mail service or consult your service provider/telephone company (page 35).
The other party complains that they cannot leave a message.	<ul style="list-style-type: none"> • The recording time is set to "Greeting Only". Select "1 Minute" or "3 Minutes" (page 35).
I cannot operate the answering system with the handset.	<ul style="list-style-type: none"> • The base unit or another handset is being used. Wait for the other user to finish. • A caller is leaving a message. Wait for the caller to finish. • The handset is too far from the base unit. Move closer.
When I try to operate the answering system with the base unit, the answer on indicator flashes for a few seconds and I cannot operate the answering system.	<ul style="list-style-type: none"> • Another handset is being used. Wait for the other user to finish. • A caller is leaving a message. Wait for the caller to finish.
I cannot operate the answering system remotely.	<ul style="list-style-type: none"> • You are entering the wrong remote access code. If you forget the remote access code, store a new remote access code again (page 33). • You are pressing the dial keys too quickly. Press each key firmly. • The answering system is turned off. Turn it on (page 34). • You are using a pulse telephone. Try again using a touch tone phone.
While recording a greeting message or listening to messages, the unit rings and recording stops.	<ul style="list-style-type: none"> • A call is being received. Answer the call and try again later.

Useful Information

Specifications

- **Standard:**
GAP (Generic Access Profile)
- **Number of channels:**
120 Duplex Channels
- **Frequency range:**
1.88 GHz to 1.9 GHz
- **Duplex procedure:**
TDMA (Time Division Multiple Access)
- **Channel spacing:**
1,728 kHz
- **Bit rate:**
1,152 kbit/s
- **Modulation:**
GFSK (Gaussian Frequency Shift Keying)
- **RF transmission power:**
Approx. 250 mW
- **Voice coding^{*1}:**
ADPCM 32 kbit/s
- **Power source:**
220–240 V, 50 Hz
- **Power consumption**
Base unit:
Standby: Approx. 1.9 W
Maximum: Approx. 6.8 W
Charger^{*1}:
Standby: Approx. 1.5 W
Maximum: Approx. 3 W
- **Operating conditions:**
5 °C–40 °C, 20 %–80 % relative air humidity (dry)
- **Dimensions:**
Base unit: Approx. 60 mm × 173 mm × 105 mm
Handset: Approx. 155 mm × 48 mm × 34 mm
Charger^{*1}: Approx. 58 mm × 87 mm × 95 mm
- **Mass (weight):**
Base unit^{*2}: Approx. 332 g
Base unit^{*1}: Approx. 260 g
Handset: Approx. 140 g

Charger^{*1}: Approx. 90 g

^{*1}KX-TG1837 only

^{*2}KX-TG1831 only

Note:

- Specifications are subject to change.
- The illustrations used in these operating instructions may differ slightly from the actual product.

Index

- A**
 - Additional handsets: 37
 - Alarm: 21
 - Answering calls: 16
 - Answering system: 31
 - Listening to messages: 32
 - Remote operation: 33
 - Turning on/off: 31
 - Auto talk: 16, 19
- B**
 - Base unit
 - Settings: 22
 - Battery
 - Charge: 12
 - Installation: 12
 - Performance: 13
 - Replacement: 12
 - Strength: 13
- C**
 - Caller ID service: 24
 - Call restriction: 23
 - Chain dial: 18
 - Character entry: 42
 - Connections: 11
 - Copy
 - Phonebook: 39
- D**
 - Date and time: 14
 - Display
 - Contrast: 19
 - Icons: 11
 - Language: 14
 - Standby mode: 19
- H**
 - Handset
 - Cancelling: 38
 - Locator: 16
 - Power on/off: 13
 - Registration: 37
 - Settings: 19
- I**
 - Intercom: 38
- K**
 - Keytones: 19
- M**
 - Making calls: 15
 - Message alert: 19
 - Missed calls: 24
 - Mute: 15
- P**
 - Pause: 15
 - Phonebook
 - Handset phonebook: 17
 - Phonebook copy: 39
 - PIN
 - Base unit: 22
 - Power on/off: 13
- R**
 - Recall: 15, 22
 - Recording
 - Greeting message: 31
 - Redialling: 15
 - Redial list: 15
 - Registration: 37
 - Repeater: 38
 - Ringtones: 19
- S**
 - SMS feature: 26
 - Speakerphone: 15
- T**
 - Transfer calls: 38
- V**
 - Voice mail: 25
 - Volume
 - Receiver: 15
 - Ringer (Base unit): 22
 - Ringer (Handset): 19
 - Speakerphone: 15



Customer Support Centre Tel. No.: 132600 or website www.panasonic.com.au

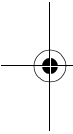

 **N52**

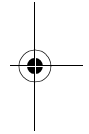

Sales Department:
Panasonic Australia Pty. Limited
Austlink Corporate Park
1 Garigal Road
Belrose
NSW 2085
AUSTRALIA

Panasonic Communications Zhuhai Co., Ltd.
3 Ping Xi 8 Lu, Nanping Keji Gongye Yuan, Zhuhai, Guangdong, China 519060

Copyright:
This material is copyrighted by Panasonic Communications Co., Ltd., and may be reproduced for internal use only. All other reproduction, in whole or in part, is prohibited without the written consent of Panasonic Communications Co., Ltd.

© 2006 Panasonic Communications Co., Ltd. All Rights Reserved.

PQQX15329ZA CC0306DM0

